

6-18GHz GaAs High Power Amplifier



Product Overview

AT-HPA-0618-3536N is GaAs Based high gain power amplifier with +36dBm output power in the frequency of 6-18GHz. The DC power requirement is +10V/3.5A at Psat. The module is with SMA connector.

The power amplifier has high gain, high linearity, low input/output return loss and flat gain response. There is no heatsink and fan in default. Option with suffix "-HF" is part number with heatsink and Fan.

More information, please visit www.atmicrowave.com

Advantages

- ✓ Frequency: 6-18GHz
- ✓ Psat:+36dBm
- ✓ Small signal gain: 35dB
- ✓ Single Power Supply

Application

- ✓ 5G Communication
- ✓ Test Equipment
- ✓ ROF (RF Over Fiber)
- ✓ Radar System

Key Features

Parameter	Min	Typical	Max
Frequency		6-18GHz	
Gain	33	35dB	
Gain Flatness		+/-4dB	
P1dB		+34dBm	
Psat		+36dBm	
Drain Supply		+10V	+12V
Idd Quiescent		2.9A	
IDD Psat		3.3A	3.8A
Input Return Loss		-12dB	
Output Return Loss		-8dB	
Heatsink Fan Bias		+12V/0.2A	
Spec Temp		25C	



Mechanical Information

Item	Description
Input Port	SMA Female
Output Port	SMA Female
Case Material	Copper
Finish	Gold Plated
Weight (With Heatsink and Fan)	400g
Size:	See outline

Absolute Maximum Ratings Table

Parameter	Value
Drain Supply	+13V
RF Input Power	+20 dBm
Operating Temperature	-20 to +55C
Storage Temperature	-65 to +150C

Very Important:

1. MUST Apply to heatsink and Fan during operation, or the amplifier will be damaged due to the high power consumption;
2. Do NOT leave Output OPEN with Bias and input power. Connect to 50 Ohms system during operation.
3. Take care that Vdd never touch Case/GND when Power ON, or the amplifier will be damaged.



Part Number Selection

Item	Description
AT-HPA-0618-3536N	In defaulted without heatsink and Fan. Heatsink and Fan required during operation.
AT-HPA-0618-3536N - HF	Including Heatsink and Fan. Fan bias is connected with PA Module's Vdd supply

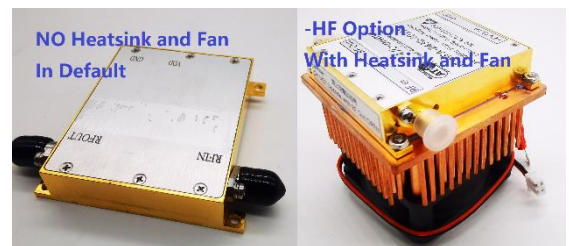

Test Data (25C)

Please note that test curves will vary slightly from unit to unit.

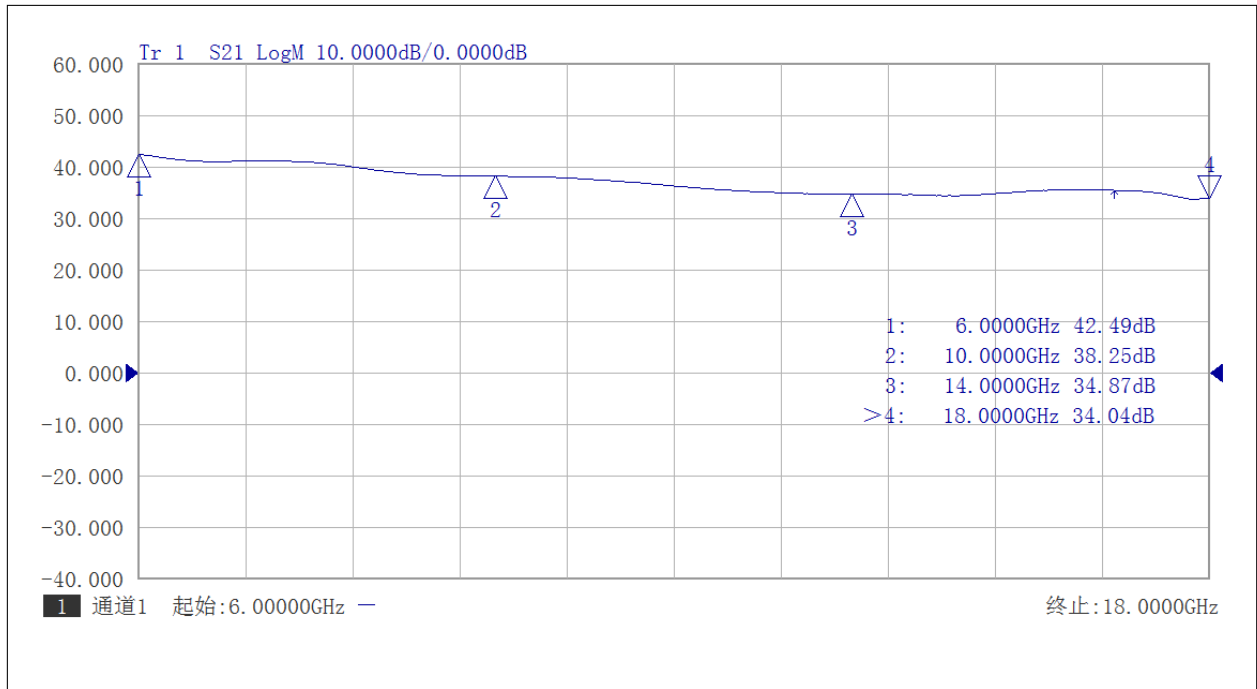

Gain vs Frequency

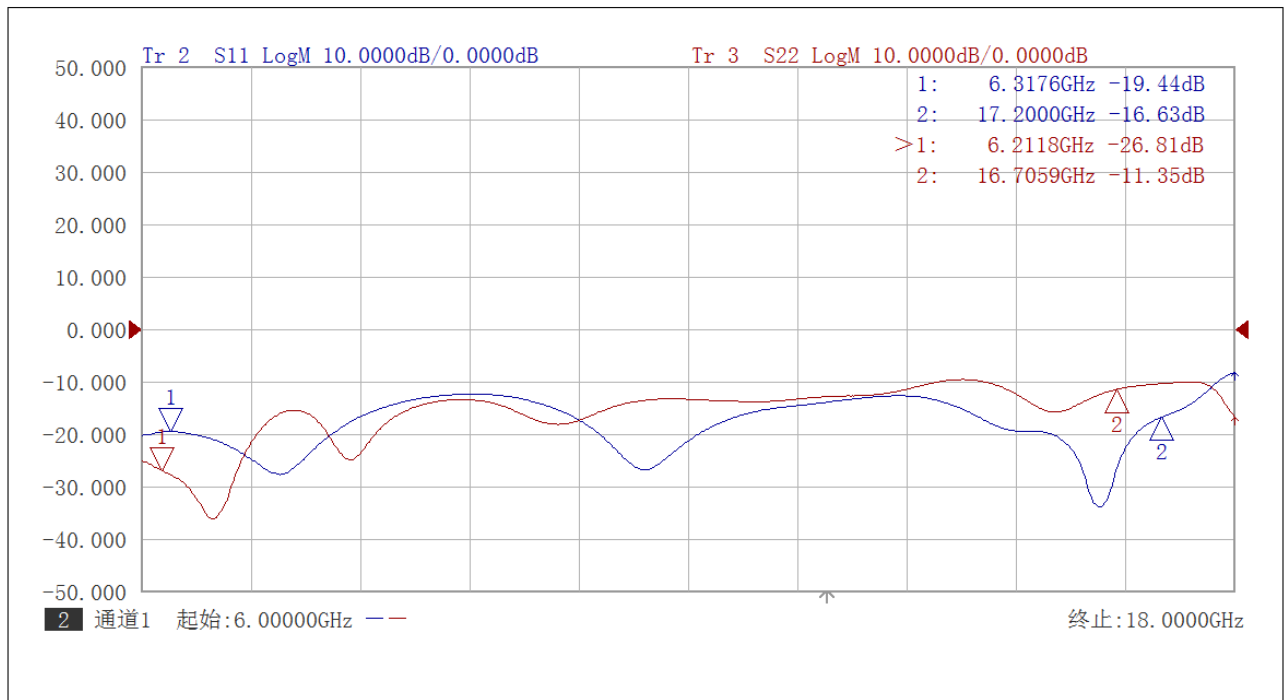

Return Loss vs Frequency



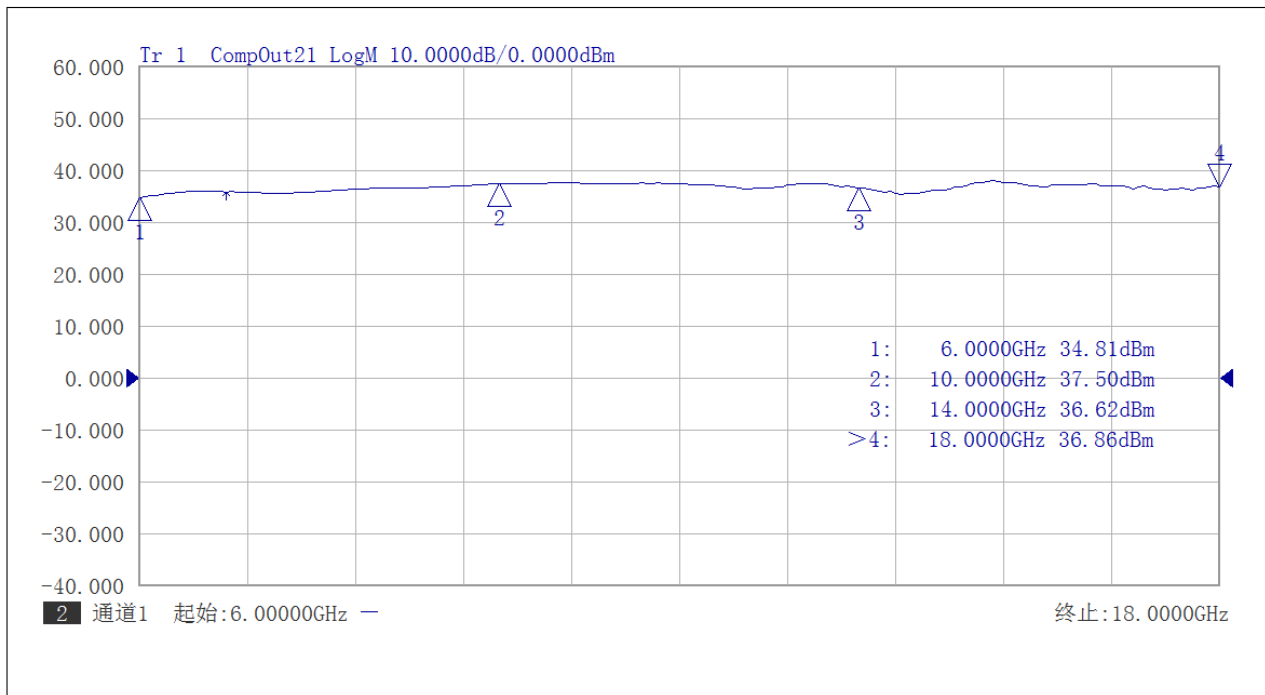

P1dB vs Frequency

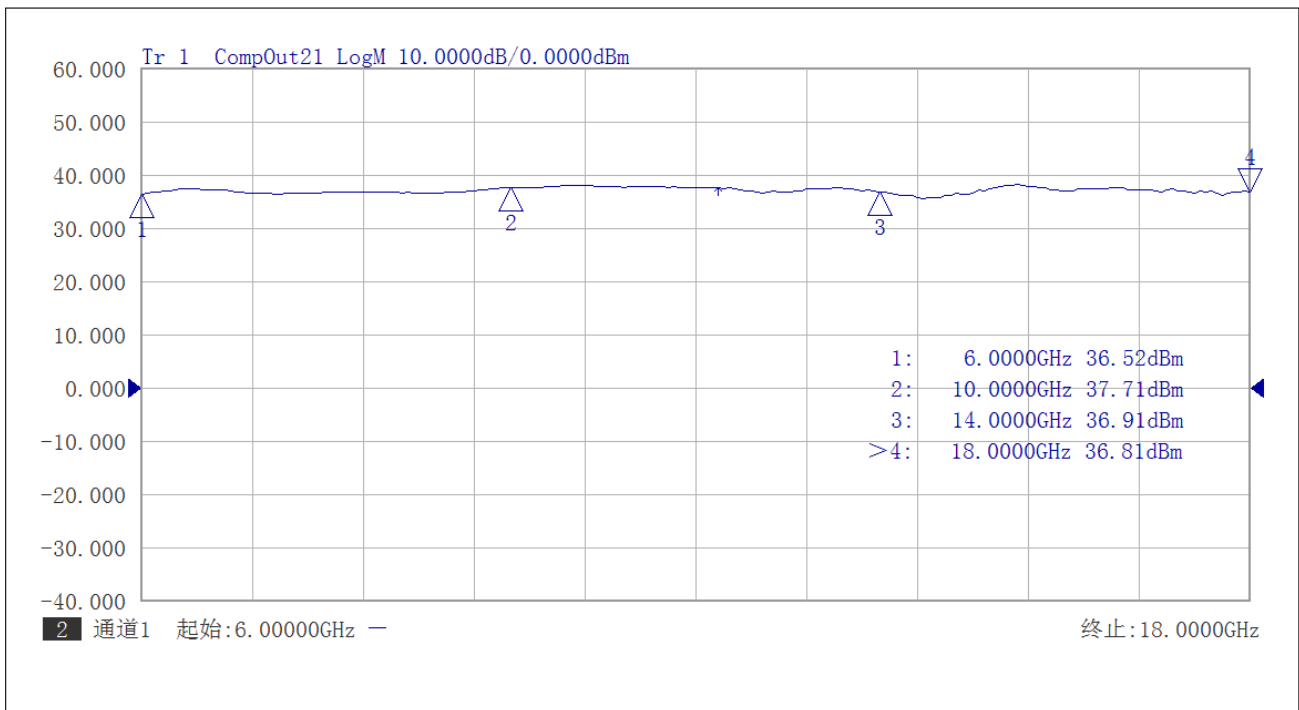

P3dB vs Frequency



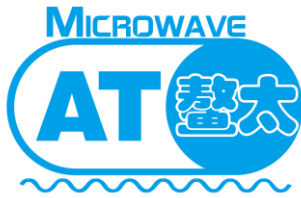

AT-HPA-0618-3536N

6-18GHz High Power Amplifier

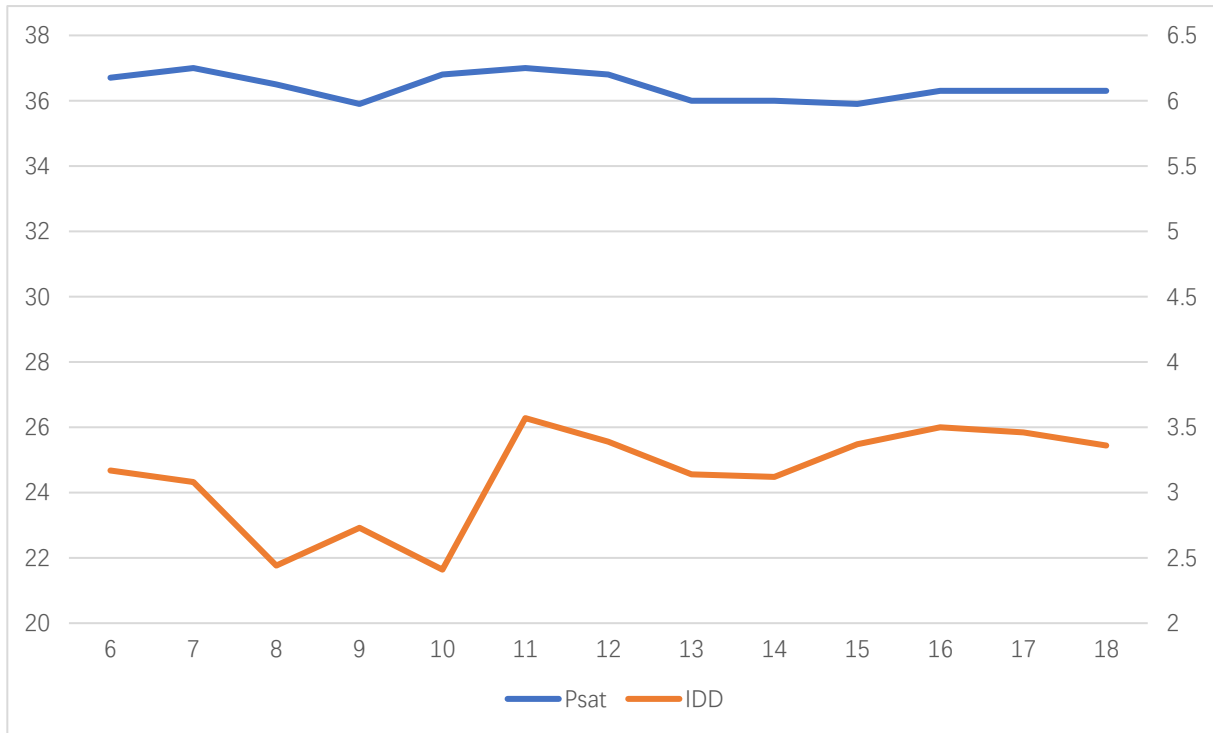

Psat and IDD vs Frequency

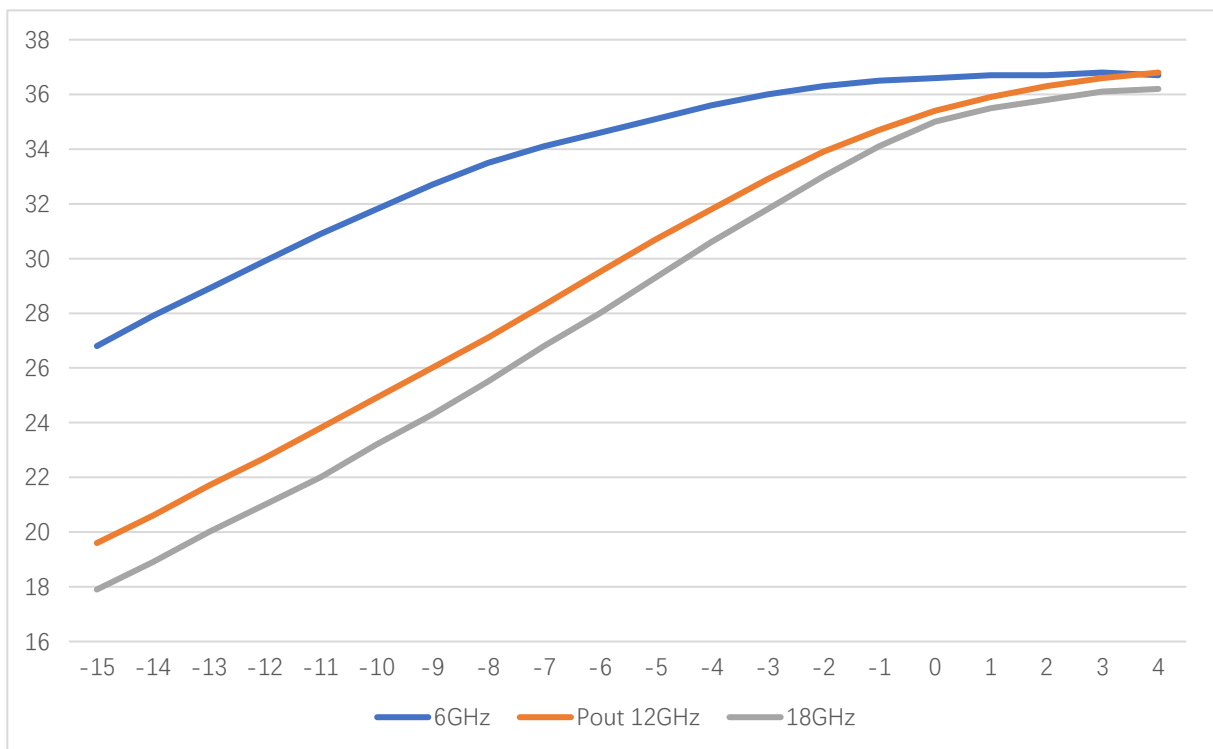

Pout vs Pin at 6/12/18GHz



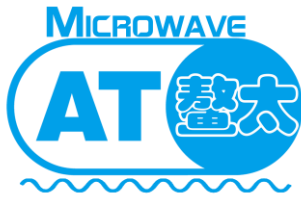

AT-HPA-0618-3536N

6-18GHz High Power Amplifier

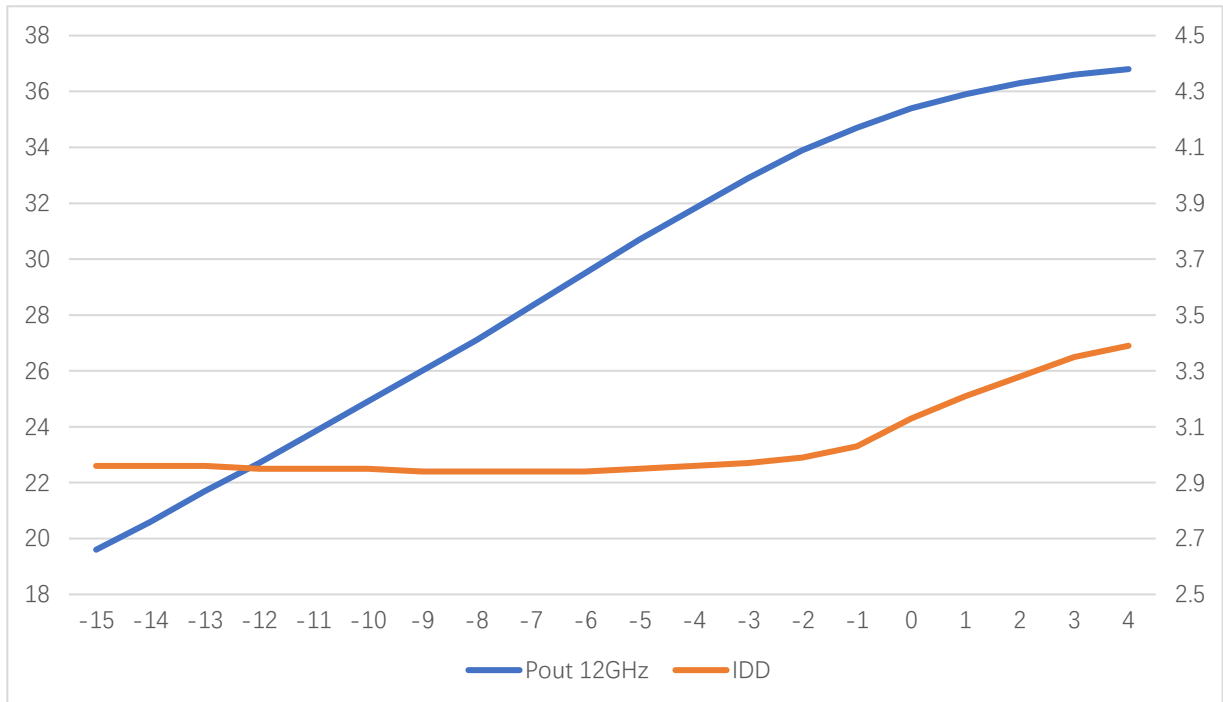

Pout and IDD vs Pin at 12GHz



Dimension: (mm)

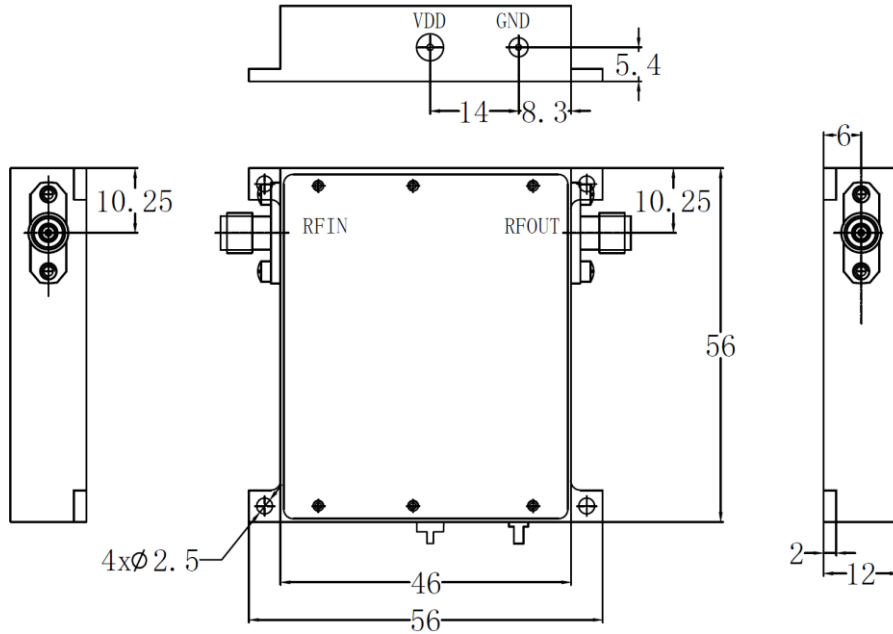

Outline without Heatsink and Fan, Heatsink Required during Operation

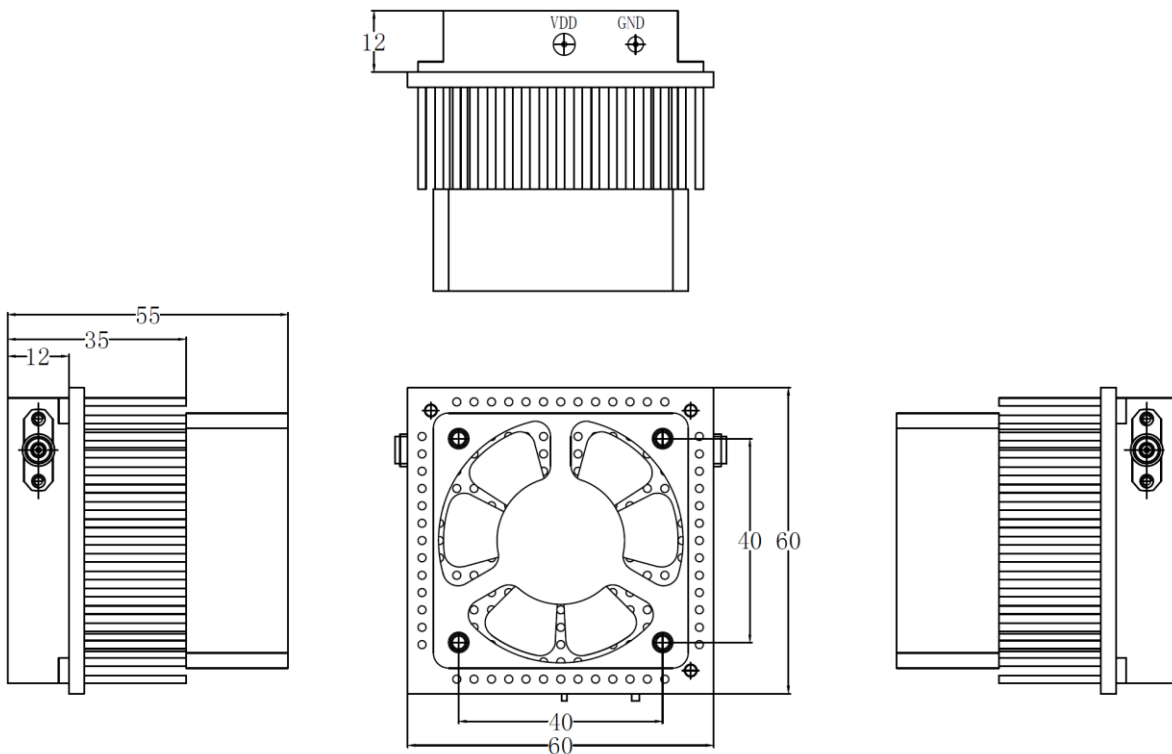

"-HF" option with Heatsink and Fan

